

Specifications

SMART Board™ interactive whiteboard system

Model 680i4

Physical specifications

SMART Board™ 680 interactive whiteboard

Size	65 1/4" W × 49 1/2" H × 5 1/8" D (165.7 cm × 125.7 cm × 13 cm)
Active screen area (maximum interactive, projected image)	61 5/8" W × 46 1/8" H (156.5 cm × 117.2 cm) 77" (195.6 cm) diagonal
Weight	30 lb. (13.6 kg)
Shipping size	73 1/2" W × 54" H × 5 1/2" D (186.7 cm × 137.2 cm × 14 cm)
Shipping weight	45 lb. (20.5 kg)

SMART UF65 projector system

Total size	18 1/2" W × 15 1/2" H × 50 1/4" D (47 cm × 39.4 cm × 127.6 cm)
Remote control	1 5/8" W × 3 3/8" H × 1/4" D (4 cm × 8.6 cm × 0.7 cm)
Extended control panel	6" W × 2 5/8" H × 2 1/4" D (15.2 cm × 6.6 cm × 5.8 cm)
Weight	13 lb. 8 oz. (6.1 kg)
Shipping size	
Accessory box	39 3/4" W × 9 1/2" H × 16" D (100.9 cm × 24.1 cm × 40.6 cm)
Projector box	19 5/8" W × 15 1/8" H × 8 1/4" D (50 cm × 38.5 cm × 21 cm)
Shipping weight	38 lb. 8oz. (17.5 kg)

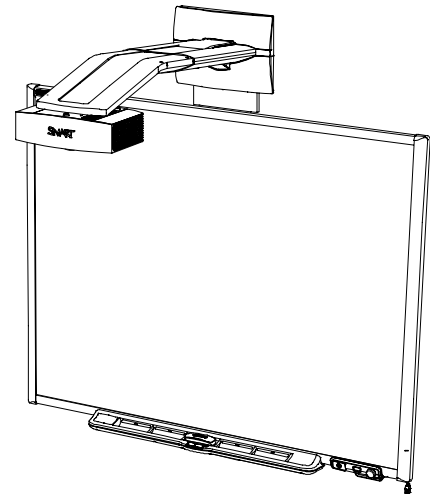

All dimensions +/- 1/8" (0.3 cm). All weights +/- 2 lb. (0.9 kg)

Standard features

Software	Includes SMART Notebook™ collaborative learning software included. See the SMART Notebook software specifications for a complete list of system requirements. Software upgrades are available at smarttech.com/software .
Environmental compliance	China EIP, EU WEEE, CPSIA, US CPSIA, Packaging, Batteries and EU RoHS
Regulatory certification	CSA (U.S./Canada), CB, CE, FCC and C-Tick
Warranty	The projector and extended control panel (ECP) have a three-year limited equipment warranty. The SMART UF65 projector lamp has a 500 hour/90 day warranty. Your interactive whiteboard has a two-year limited equipment warranty or a five-year limited equipment warranty upon registration. See warranty documents for details.
Cables	Includes the necessary cables to connect the projector to the ECP. However, you must supply the appropriate input cables for your personal computer and devices.

Interactive whiteboard features

Pen tray	Optical sensors in the pen tray detect when you lift a pen or the eraser from the tray. LEDs indicate the active tool.
Pens and eraser	Black, red, green and blue pens and a rectangular eraser
Resolution	Touch resolution is approximately 4000 × 4000.
Screen surface	The hard-coated surface is tear proof, optimized for projection, compatible with dry-erase markers and cleans easily with whiteboard cleaner.
Digitizing technology	Resistive technology
Frame finish	Dark gray (approximates Pantone® Charcoal Gray 18-0601 TPX) and Ultrasonic Chrome (approximates Cool Gray 7)
Wall-mount bracket	Includes a 32" (81.3 cm) wide bracket, five screws and five drywall anchors to support your wall-mounted interactive whiteboard
Projector mounting template	The template ensures simple installation and accurate alignment between the SMART UF65 projector and your SMART Board 680 interactive whiteboard.
Installation instructions	The installation instructions for your SMART Board 680i4 interactive whiteboard system are included in the SMART UF65 projector boom box. Don't use the installation instructions included in your SMART Board interactive whiteboard box when installing the SMART Board 680i4 interactive whiteboard system. Additional documentation is available on the SMART Support website .
Theft prevention	Pen tray locking feature and Kensington® security slot on the pen tray

SMART UF65 projector system features

System components	SMART UF65 projector, boom mount with a limit strap (including a controlled-collapse feature), ECP, remote control and all necessary input cables from the ECP to the projector
Image adjustment	The mounting boom includes three mechanical adjustments for aligning the projector image with your interactive whiteboard. The projector also has a focus lever and a digital on-screen menu for brightness, contrast and other image-related attributes.
Display type	True XGA 1024 × 768 projector
3D technology	3D-ready projector using DLP® Link™ technology
Display technology	The projection engine uses DLP® technology by Texas Instruments™, providing BrilliantColor™ performance and quality Gamma 2.2 correction with Bright Room, Dark Room, sRGB, User and SMART Presentation modes.
Brightness	Estimated at 2000 lumens (typical) at a CCT of 6500 K by the IEC method
Lamp life	3000 hours (Standard 200 W mode) or 5000 hours (Economy 160 W mode)
Aspect ratio	4:3 native, with support for 16:9, 16:10 and 5:4 ratios
Contrast ratio	2000:1
Video system compatibility	NTSC, NTSC 4.43, PAL, PAL-N, PAL-M, SECAM
Video interface compatibility	Composite, S-video, and VESA RGB, with additional interface support for Component YPbPr and Component YCbCR inputs with the proper adapters (not included)
Video format compatibility	Native 4:3 aspect ratio XGA projector resolution. With scaling, supports VGA, SVGA, SXGA, Quad VGA, SXGA+ and UXGA formats.
Synchronization	Auto image synchronization (auto tracking, frequency, position adjustment, source detect and phase detect)
Mounting hardware	Includes hardware for mounting the SMART UF65 projector to framed and solid walls. Includes a safety tether and limit strap.
Input/output connections	<ul style="list-style-type: none">• Two HD DB15F connectors – RGB video input from two computers via VGA connectors• HD DB15F connector – video output pass-through of Video Input 1 signal• 4-pin mini-DIN connector – S-video input• One pair of audio jacks (RCA, stereo) – reserved for use with S-video• Composite video connector – RCA-style video input• One pair of audio jacks (RCA, stereo) – reserved for use with composite video• Two 3.5 mm stereo jacks – audio input from two computers• 3.5 mm stereo jack – audio output to connect speakers• RJ45 – network connection for SNMP management and control, and for sending e-mail alerts

4 | **SPECIFICATIONS** – SMART BOARD INTERACTIVE WHITEBOARD SYSTEM –
MODEL 680i4

	<ul style="list-style-type: none">• 4-pin power mini-DIN 5V 2A connector (reserved for ECP harness cable)• 7-pin mini-DIN connector (reserved for ECP harness cable)
Projector fan	<ul style="list-style-type: none">• Standard speed – 0 to 6000' (0 m to 1829 m): 41°F to 95°F (5°C to 35°C)• High speed – 6000' to 6800' (1829 m to 2073 m): 41°F to 86°F (5°C to 30°C)
Projector noise	36 dBA (high fan speed) or 31dBA (standard fan speed), measured using JIS method
Power requirements	100V AC to 240V AC, at 50 Hz to 60 Hz
Power cable	Includes a 14' 9" (4.5 m) power cable
External control	The RS-232 connector is configured to accept control codes from your computer or a room control system.
Power consumption	270 W in High Brightness. 225 W in Economy mode. <5 W in Standby mode.
Remote control	Provides an alternative method of controlling the SMART UF65 projector settings
Theft protection	The SMART UF65 projector system features an optional padlocked ring to prevent theft. A Kensington security slot is provided to affix the system to a wall as a visual and physical theft deterrent.

Extended control panel (ECP) features

Input/output connections	<ul style="list-style-type: none">• Two USB A receptacles for peripheral devices: one on the back and one on the front• Three RCA jacks (composite video input) and associated audio input• DB15-M socket (ECP harness cable only)• USB B receptacle (secondary computer)• RJ11 6-wire jack for SC9 connector cable when using the system with a SMART Hub SE240• USB B receptacle (primary computer)• USB A receptacle (SMART Board interactive whiteboard only)
Volume control	Controls sound range
Power button	Turns the projector on and off
Input selection buttons	Selects the projector video and audio inputs through the available input sources: VGA1, VGA2, Composite and S-video. The USB Hub supports dual computer switching.

Storage and operating specifications

- Storage**
- Maximum storage temperature: 122°F (50°C)
 - Minimum storage temperature: -40°F (-40°C)
- Operation**
- Using standard fan speed, 41°F to 95°F (5°C to 35°C) from sea level to an altitude up to 6000' (0 m to 1829 m)
 - Using high fan speed, 41°F to 86°F (5°C to 30°C) from 6000' to 6800' (1829 m to 2073 m)
 - In Service mode, 41°F to 86°F (5°C to 30°C) from 6800' to 9800' (2073 m to 2987 m)

SMART order numbers

- SB680i4** 77" (195.6 cm) diagonal SMART Board 680 interactive whiteboard with a SMART UF65 projector system
- 20-01032-20** Replacement projector lamp

Optional accessories

- RPEN-ER** Replacement set of four pen tray pens (black, red, green and blue) and a rectangular eraser
- RPEN** Replacement set of four pen tray pens (black, red, green and blue)
- SBA-L** Projection Audio System for the SMART Board 600i4 interactive whiteboard system
- WC6D** Wireless Bluetooth® Connection for SMART Board 600 and D600 series interactive whiteboards

Physical dimensions

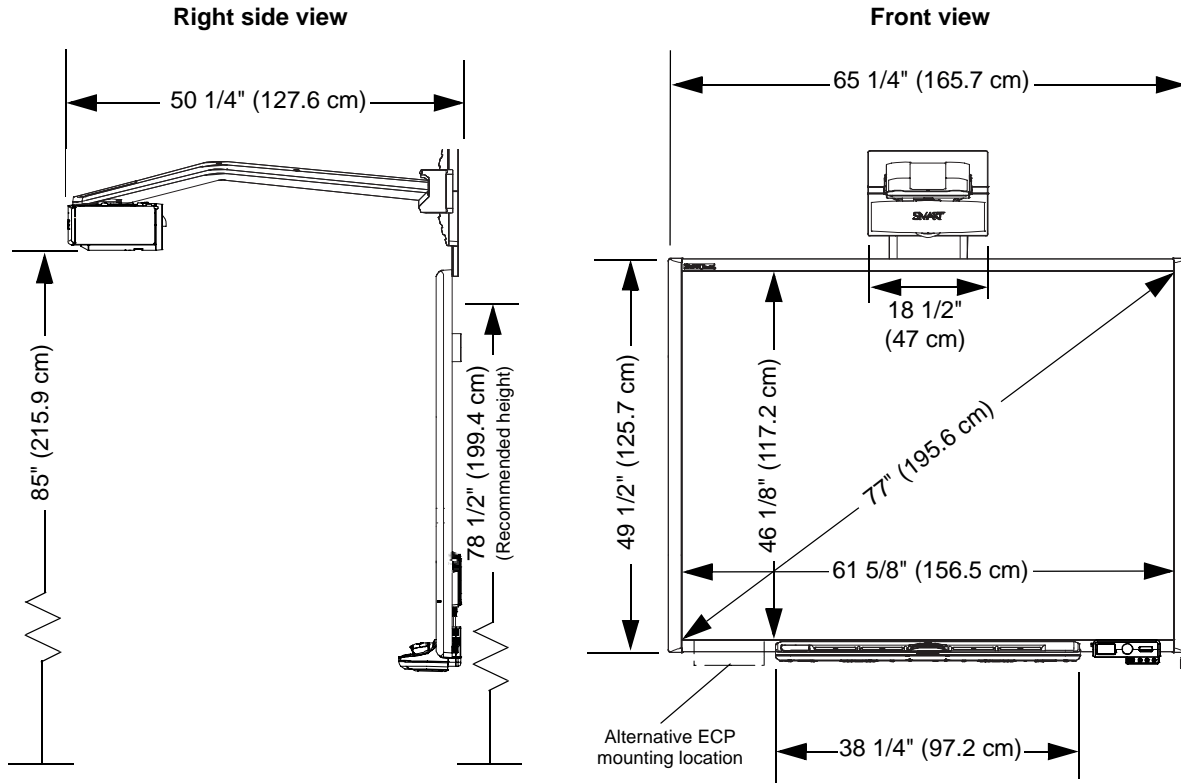

ECP right side view

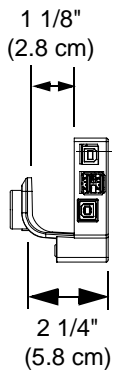

ECP front view

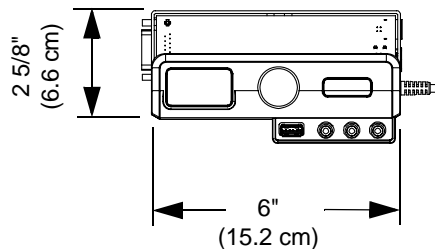

Projector mounting bracket

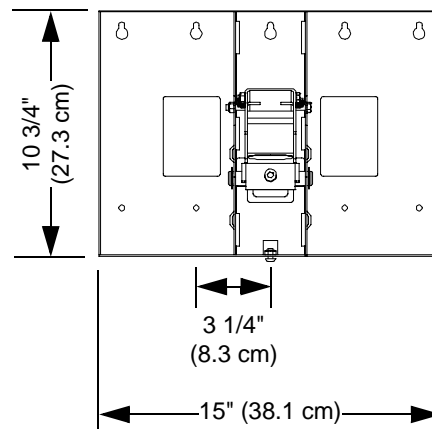

www.smarttech.com/support www.smarttech.com/contactsupport
 Support +1.403.228.5940 or Toll Free 1.866.518.6791 (U.S./Canada)

